



Published 1999-04-01

INTERNATIONAL ORGANIZATION FOR STANDARDIZATION • МЕЖДУНАРОДНАЯ ОРГАНИЗАЦИЯ ПО СТАНДАРТИЗАЦИИ • ORGANISATION INTERNATIONALE DE NORMALISATION

Road vehicles — Ignition coils — Electrical characteristics and test methods

TECHNICAL CORRIGENDUM 1

Véhicules routiers — Bobines d'allumage — Caractéristiques électriques et méthodes d'essai

RECTIFICATIF TECHNIQUE 1

Technical Corrigendum 1 to International Standard ISO 13476:1997 was prepared by Technical Committee ISO/TC 22, *Road vehicles*, Subcommittee SC 1, *Ignition equipment*.

This material is reproduced from ISO documents under International Organization for Standardization (ISO) Copyright License Number IHS/ICC/1996. Not for resale. No part of these ISO documents may be reproduced in any form, electronic retrieval system or otherwise, except as allowed in the copyright law of the country of use, or with the prior written consent of ISO (Case postale 56, 1211 Geneva 20, Switzerland, Fax + 41 22 734 10 79), IHS or the ISO Licensor's members.

Page 6, subclause 4.7.3

In the second sentence, replace "(0,00 5 %/ V_{max})" with "(0,000 5 %/ V_{max})".

Page 7, subclause 5.3

In the formula for the primary current reference time (t_{ref}), replace R_x with R_p .

**INTERNATIONAL
STANDARD**

**ISO
13476**

First edition
1997-12-15

**Road vehicles — Ignition coils — Electrical
characteristics and test methods**

*Véhicules routiers — Bobines d'allumage — Caractéristiques électriques et
méthodes d'essai*



Reference number
ISO 13476:1997(E)

ISO 13476:1997(E)**Foreword**

ISO (the International Organization for Standardization) is a worldwide federation of national standards bodies (ISO member bodies). The work of preparing International Standards is normally carried out through ISO technical committees. Each member body interested in a subject for which a technical committee has been established has the right to be represented on that committee. International organizations, governmental and non-governmental, in liaison with ISO, also take part in the work. ISO collaborates closely with the International Electrotechnical Commission (IEC) on all matters of electrotechnical standardization.

Draft International Standards adopted by the technical committees are circulated to the member bodies for voting. Publication as an International Standard requires approval by at least 75 % of the member bodies casting a vote.

International Standard ISO 13476 was prepared by Technical Committee ISO/TC 22, *Road vehicles*, Subcommittee SC 1, *Ignition equipment*.

© ISO 1997

All rights reserved. Unless otherwise specified, no part of this publication may be reproduced or utilized in any form or by any means, electronic or mechanical, including photocopying and microfilm, without permission in writing from the publisher.

International Organization for Standardization

Case postale 56 • CH-1211 Genève 20 • Switzerland

Internet central@iso.ch

X.400 c=ch; a=400net; p=iso; o=isocs; s=central

Printed in Switzerland

Road vehicles — Ignition coils — Electrical characteristics and test methods

1 Scope

This International Standard applies to ignition coils for inductive energy storage. It defines test methods for ignition coils used in ignition systems with solid state switching of spark ignited internal combustion engines.

2 Parameters

2.1 General

The performance of an ignition coil is governed by three major sets of parameters:

- those inherent within the coil;
- those associated with the external conditions affecting the primary side of the coil;
- those affecting the output or secondary side of the coil.

The behaviour of the coil at its low tension terminals shall be known to the supplier of the interruption system. Similarly the output at the high tension (HT) terminals shall be known to those concerned with specifying the spark plug demand and the routing of the HT output. Several of the parameters to be derived interact and they shall, therefore, be quoted as a complete set.

The parameters listed in 2.2 to 2.4 do not provide a direct indication of the operational temperature rise of the coil.

2.2 Coil construction parameters

- Primary resistance (R_p)
- Primary inductance (L_p) (for reference only)
- Turns ratio (for reference only)
- Secondary resistance (R_s) (for reference only)
- Primary current reference time (t_{ref}) (for a limited range of R_p)
- Primary leakage inductance (L_{pl})

2.3 Primary side parameters (switching)

- Nominal primary interruption current (I_{Np})
- Primary clamp voltage (U_{plm})

2.4 Output parameters, governed by construction and switching

- Maximum secondary output voltage (U_{sm})
- Ignition limiting load resistance (R_{15kV})
- Secondary voltage rise time (t_{svr}) (timing retard)
- Zener discharge energy (E_{zd})
- Zener discharge duration (t_{zsd})
- Maximum zener discharge current (I_{zdm})

3 Test conditions

All tests shall be done at an ambient temperature of (23 ± 5) °C and a relative humidity between 45 % and 75 %.

Before measuring resistance, ensure the temperature of the coil is stable.

All equipment shall be calibrated before measurements are made.

4 Test equipment

4.1 Coil

For the test purposes the coil shall be arranged as shown in figures 1 and 2. For double ended coils, one HT terminal shall be grounded through a 0,5 kV zener diode, simulating the exhaust spark.

4.2 d.c. source

A d.c. source shall be used having a 10 % to 90 % transient recovery time of not more than 50 μ s over the load range encountered in use. It shall have no more than 50 mV variation in average voltage from no load to full ignition system load and no more than 100 mV peak-to-peak ripple over the same load range. The power supply shall be positioned immediately adjacent to the system being tested.

This d.c. source shall be adjusted to:

(13,5 \pm 0,1) V for 12 V systems;

(27 \pm 0,2) V for 24 V systems.

4.3 Oscilloscope

An oscilloscope with a maximum rise time of 35 ns, with a minimum band pass of 10 MHz shall be used (P1, P2, P3, P4). The overall measuring inaccuracy including compensated and calibrated voltage and current probes (see 4.4 and 4.5) shall be less than:

1 % for voltages below or equal to 1 500 V;

3 % for voltages above 1 500 V;

1 % for current measurements.

4.4 Voltage probes

4.4.1 A high voltage probe P2 with an input capacitance smaller than or equal to 5 pF and an input resistance of 100 M Ω or greater shall be used.

4.4.2 Voltage probes P3 and P4 with a minimum band pass of 10 MHz shall be used.

4.5 Current probe

A current probe P1 suitable for d.c. to 10 MHz shall be used.

4.6 Interruption system

An interruption system set to $(50 \pm 0,5)$ Hz shall be used.

4.7 Test arrangement A

4.7.1 Only non-resistive high voltage cables and low-resistance low voltage cables shall be used.

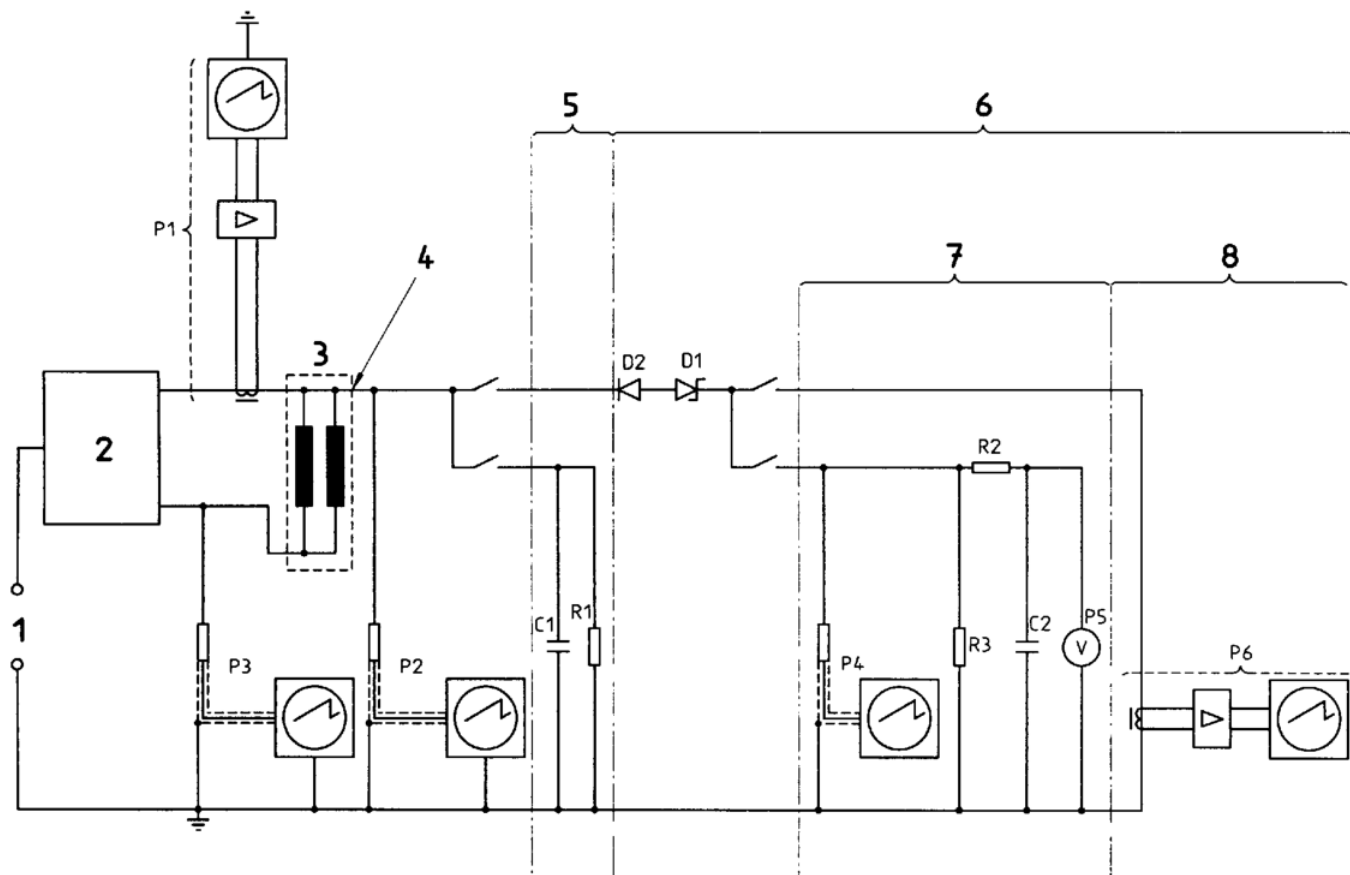

Key

- | | | |
|----------------------------|----------------------------------|---------------------------------------|
| C1 Ballasting capacitor | P1 Current probe | P6 Zener discharge current probe |
| C2 Capacitor 47 μ F | P2 High voltage probe | R1 High voltage resistor 1 M Ω |
| D1 Zener diode string 1 kV | P3 Primary voltage probe | R2 Resistor 10 k Ω |
| D2 High voltage diode 5 kV | P4 Zener discharge voltage probe | R3 Resistor 100 Ω |
| | P5 Volt meter | |

- 1 Constant d.c. voltage power supply, battery optional
- 2 Interruption system
- 3 Ignition coil
- 4 Cut point
- 5 Test arrangement A
 - maximum secondary output voltage
 - secondary voltage rise time
- 6 Test arrangement B
 - primary current reference time
 - zener discharge energy and duration
- 7 Evaluation B1 RC network, example
- 8 Evaluation B2 Integration method, example

NOTE — If the discharge energy is not evaluated by R2, C2 and P5 (see test evaluation B1), these components can be deleted. P4 can be replaced by the current probe P6, and R3 replaced by a short circuit (see test evaluation B2).

Figure 1 — Test circuit for single ended coils

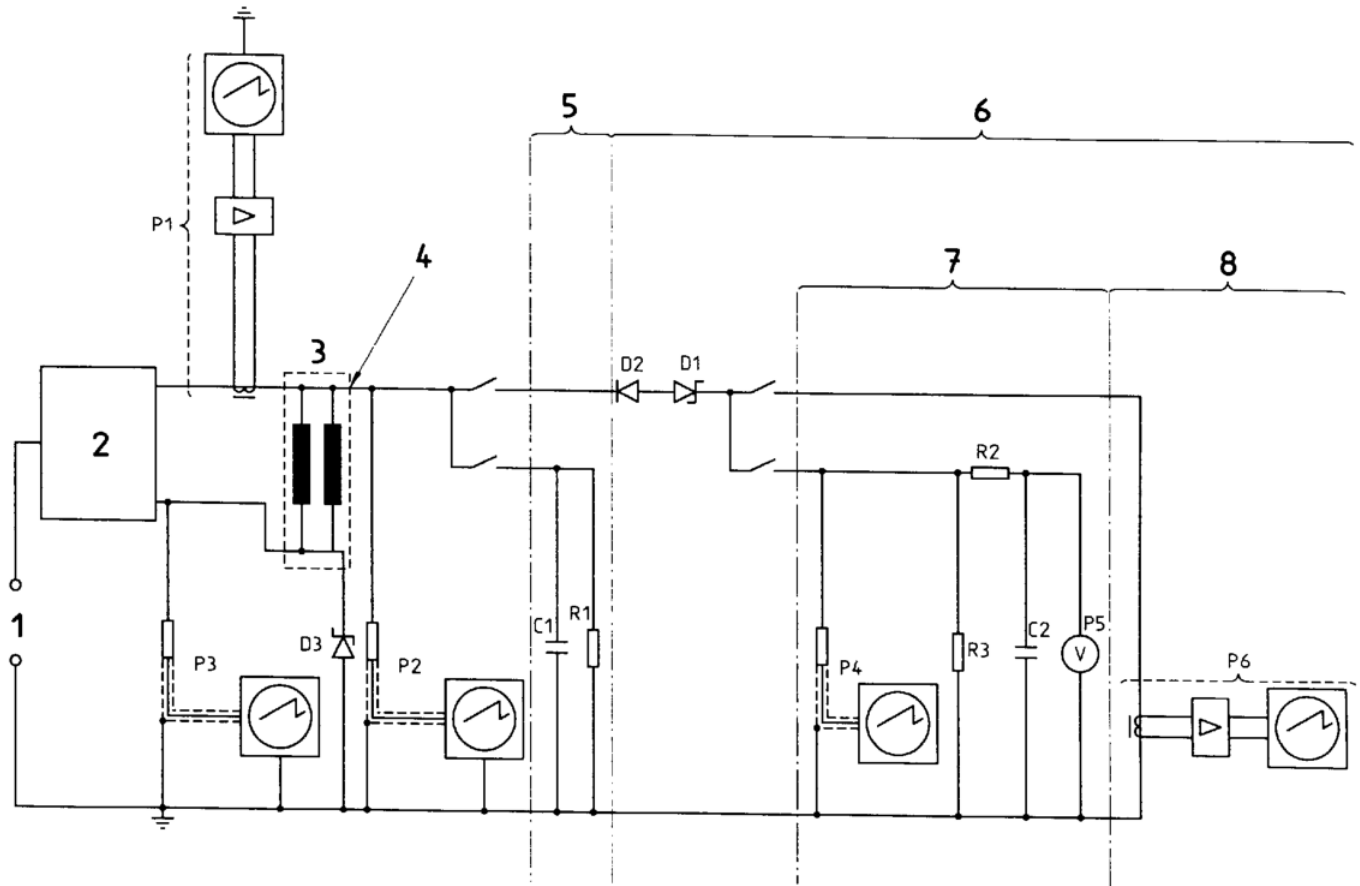

Key

- | | | |
|------------------------------|----------------------------------|---------------------------------------|
| C1 Balasting capacitor | P1 Current probe | P6 Zener discharge current probe |
| C2 Capacitor 47 μ F | P2 High voltage probe | R1 High voltage resistor 1 M Ω |
| D1 Zener diode string 1 kV | P3 Primary voltage probe | R2 Resistor 10 k Ω |
| D2 High voltage diode 5 kV | P4 Zener discharge voltage probe | R3 Resistor 100 Ω |
| D3 Zener diode string 0,5 kV | P5 Volt meter | |

- 1 Constant d.c. voltage power supply, battery optional
- 2 Interruption system
- 3 Ignition coils
- 4 Cut point
- 5 Test arrangement A
 - maximum secondary output voltage
 - secondary voltage rise time
- 6 Test arrangement B
 - primary current reference time
 - zener discharge energy and duration
- 7 Evaluation B1 RC network, example
- 8 Evaluation B2 Integration method, example

NOTES

- 1 D3 simulates the exhaust spark. If the discharge energy is not evaluated by R2, C2 and P5 (see evaluation B1), these components can be removed.
P4 can be replaced by a current probe P6, and R3 replaced by a short circuit (see evaluation B2).
- 2 Attention should be paid to the to polarity of secondary circuit.

Figure 2 — Test circuit for double ended coils

4.7.2 The capacitance C_{total} simulates the capacitance of the cables and spark plugs as normally encountered on the engine. This capacitance shall be a low dissipation factor (not greater than 3 % at 1 kHz) secondary ignition cable of a length such that in conjunction with the capacitor and high tension probe the total capacitance is:

50 pF to 55 pF for ignition systems with distributor;

25 pF to 30 pF for static ignition systems with single ended coils;

50 pF to 55 pF for static ignition systems with double ended coils.

NOTE 1 Other capacitance values may be agreed upon, depending on the application.

NOTE 2 The total capacitance is the capacitance measured from the cut point, including every parasitic capacitance (including for example HV probe capacitance):

$$C_{\text{total}} = C_1 + C_{\text{parasitic}}$$

NOTE 3 Example of measurement of total capacitance by the cut-frequency method, using test arrangement A (this will not establish the dissipation factor of the capacitance):

The cut-frequency method powers the load from a sinusoidal generator through a series resistor, e.g. $R = 10 \text{ k}\Omega$. At a very low frequency, note the value of the voltage across C_1 (V_0), then increase the frequency until this voltage becomes equal to $V_0 \cdot 0,7$ (-3 dB), then note the frequency $f_{3\text{dB}}$.

Calculate the capacitance using the following formula.

$$C_{\text{total}} = \frac{1}{2 \times \pi \times f_{3\text{dB}} \times R}$$

During this measurement, the output voltage of the sinusoidal generator shall be kept constant.

4.7.3 The resistance value R_1 simulates various degrees of lead or carbon fouling of spark plugs. Each resistor used shall have a low voltage coefficient (0,00 5 %/ V_{max}), be non-inductive, approximately 10 W and 1 M Ω with a relative tolerance of ± 5 % at 20 kV. They shall be connected in parallel with the ballasting capacitor for the measurement of ignition limiting load resistance (see 5.5).

4.8 Test arrangement B

4.8.1 A zener diode string of 1 kV for single ended coils and two zener diode strings of 1 kV and 0,5 kV for double ended coils, each with a zener voltage tolerance of ± 5 % under test conditions, shall be used.

4.8.2 A 5 kV high voltage diode D2 shall be used.

4.8.3 The components listed in 4.8.3.1 to 4.8.3.3 are given as an example for evaluating the energy (see 5.6 and figures 1 and 2).

4.8.3.1 A d.c. voltmeter P5 with an input resistance of at least 10 M Ω and with sufficient resolution to easily indicate differences of 1 mV.

4.8.3.2 A filtering network composed of a resistance $R_2 = 10 \text{ k}\Omega$ nominal and a capacitor $C_2 = 47 \text{ }\mu\text{F}$ nominal with a leakage less than 1 $\mu\text{A/V}$.

4.8.3.3 A non inductive resistor R_3 (shunt resistor) of 100 Ω with a relative tolerance of ± 1 %.

5 Electrical characteristics

5.1 Primary resistance (R_p)

A 4 points or corrected 2 points method shall be used, followed by a correction to 20 °C. For copper winding, the following formula shall be used:

$$R_p = \frac{R_x}{1 + 0,0039 (T_x - 20)}$$

where

R_x is the resistance measured at a temperature T_x ;

R_p is the corrected primary resistance.

5.2 Secondary resistance (R_s) (for information only)

The nominal secondary resistance shall be supplied by the coil manufacturer.

5.3 Primary current reference time (t_{ref})

For this measurement a switch shall be used which remains within the normal saturation region at nominal primary interruption current (I_{Np}). The switch shall not have means for active current limitation.

Primary current reference time enables switching circuit and engine designers to calculate the requirements and behaviour of an ignition system at the design stage. Measured times are corrected for variation of circuit values that can exist at various measurement locations.

The components shall be interconnected as shown in figures 1 or 2, test arrangement B. The test procedure shall be as follows.

- Measure the time t_1 for increasing the current from 0 to nominal primary interruption current (I_{Np}).
- Connect a voltage probe P3 to the primary of the coil and measure, according to figure 3, V_{ce0} , V_{ce1} , t_1 .
- Measure the wiring resistance R_w .
- Calculate the switch resistance R_c using the following formula:

$$R_c = \frac{(V_{ce1} - V_{ce0})}{I_{Np}}$$

Calculate the primary current reference time (t_{ref}) using the following formula:

$$t_{ref} = t_1 \times \frac{(R_x + R_w + R_c)}{(R_p + R_{wref} + R_{cref})} \times \frac{\ln \left(1 - \frac{(R_p + R_{wref} + R_{cref}) \times I_{Np}}{U_{sup} - V_{ce0ref}} \right)}{\ln \left(1 - \frac{(R_p + R_w + R_c) \times I_{Np}}{U_{sup} - V_{ce0}} \right)}$$

where

$$V_{ce0ref} = 1 \text{ V};$$

$$R_{cref} = 0,2 \ \Omega;$$

$$R_{wref} = 0,1 \ \Omega.$$

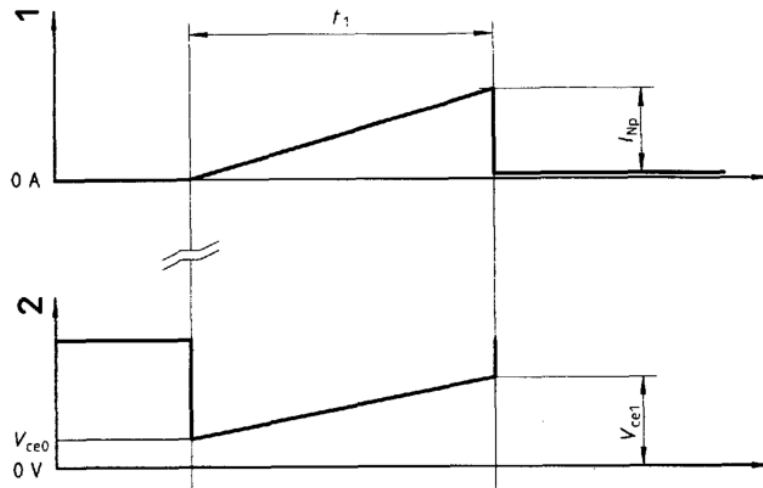

Key

- 1 Primary current
- 2 Primary voltage

Figure 3 — Waveforms at the primary side

5.4 Primary leakage inductance (L_{pl})

The following test procedure shall be used.

- Short circuit the secondary winding of the ignition coil.
- Measure the primary inductance by an LCR bridge (measuring frequency 1 kHz).

For coils manufactured with secondary HV diode, the value shall be supplied by the coil manufacturer.

5.5 Maximum secondary output voltage, ignition limiting load resistance and secondary voltage rise time

5.5.1 Adjustment

With the primary switching components as in figure 1 and with the coil loaded with the total capacitance (C_{total}) set the interruption current to its nominal value I_{Np} (see figure 3) with a maximum deviation of 1 %. Adjust the primary clamp to give the specified nominal voltage (U_{plim}) with a maximum deviation of 3 % (see figure 4).

Measure the maximum secondary output voltage U_{sm} .

5.5.2 Measurement

With the circuit connected as in figure 1, test arrangement A, and the coil loaded with the total capacitance (C_{total}) (see 4.7.2), and the resistance R1 (see 4.7.3) set to 1 M Ω , measure the following (see figure 5):

- a) secondary voltage rise time between -1,5 kV and -15 kV (t_{sur});
- b) the ignition limiting load resistance (R_{15kV}), determined for a maximum secondary output voltage of -15 kV by selecting various values of R1. If a resistor is not available to produce exactly a -15 kV output, interpolation between available values shall be used.

For double ended coils, the tests shall be performed for positive and negative polarities.

For those ignition coils whose maximum secondary output voltage does not exceed -15 kV when loaded with the total capacitance and the resistance R1 of 1 M Ω , these coils shall be tested with R1 set to infinity.

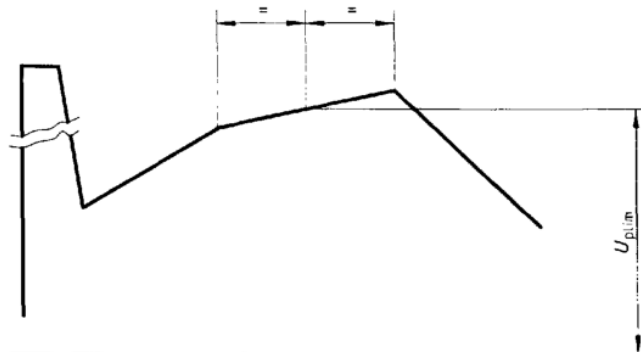
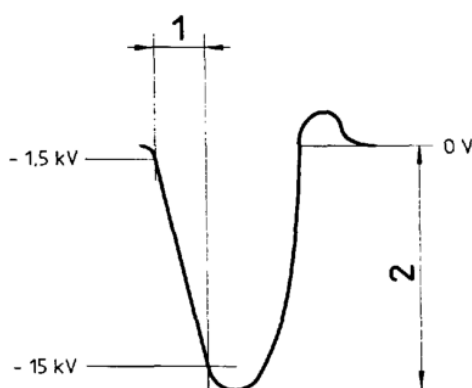

Figure 4 — Primary clamp voltage (U_{plim})



Key

- 1 Secondary voltage rise time
- 2 Maximum secondary output voltage

Figure 5 — Secondary output voltage

5.6 Zener discharge energy (E_{zd}), zener discharge duration (t_{zd}) and maximum zener discharge current (I_{zdm})

For this measurement, the interruption current shall be as close as possible to the nominal primary interruption current (I_{np}).

The zener discharge energy is computed by integration of the product of zener discharge current and zener discharge voltage over the zener discharge duration.

Figure 1, evaluation B1, and figure 2, evaluation B1, and the following show one optional method of obtaining the integration (see figure 6).

- Record the value of P5 (U_{mean}) after read out stabilization.
- Using the probe P2 (see figure 1), record the zener discharge voltage (U_{zd}) on the oscilloscope during zener discharge duration t_{zd} (see figure 5).
- Calculate the zener discharge energy (E_{zd}), expressed in joules, from the following formula:

$$E_{zd} = \frac{U_{mean} \times U_{zd}}{\text{frequency} \times R_3} \text{ J}$$

- Record the zener discharge duration and the maximum zener discharge current (I_{zdm}) on the oscilloscope, as shown in figure 6.

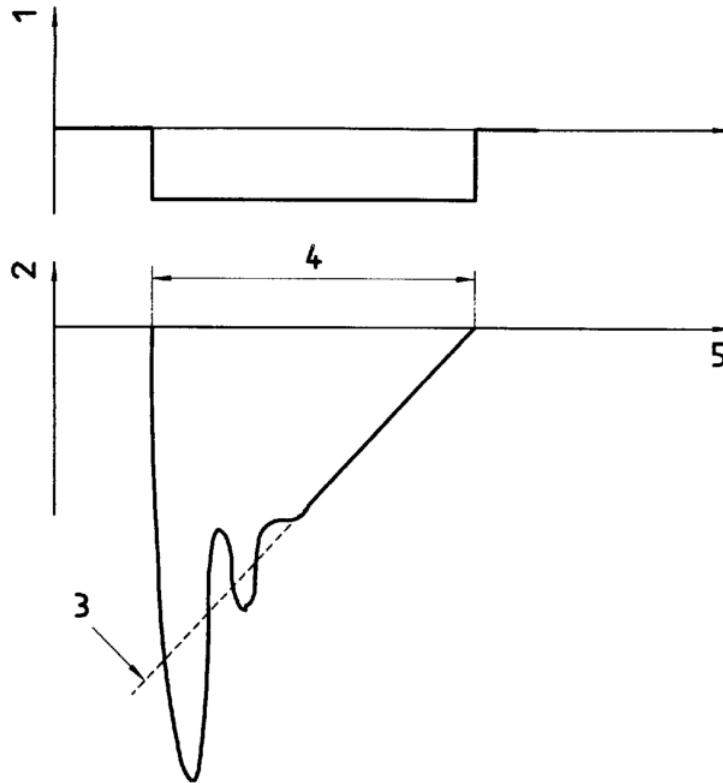

Key

- 1 Zener discharge voltage, U_{zd}
- 2 Zener discharge current, i_{zd}
- 3 Maximum zener discharge current
- 4 Zener discharge duration (t_{fzd})
- 5 Time

Figure 6 — Waveform at the secondary side

6 Test report

The test report shall include the following electrical characteristics:

- primary resistance (R_p);
- secondary resistance (R_s);
- primary current reference time (t_{ref});
- primary leakage inductance (L_{pl});
- maximum secondary output voltage (U_{sm}) at C_{total} ;
- ignition limiting load resistance (R_{15kV});
- secondary voltage rise time (t_{svr});
- zener discharge energy (E_{zd});
- zener discharge duration (t_{zd});
- maximum zener discharge current (i_{zdm});
- zener discharge voltage (U_{zd}).

It shall also include the test conditions, test circuit, supply voltage (U_{sup}), primary nominal interruption current (I_{np}), and primary clamp voltage (U_{pim}).

ICS 43.060.50

Descriptors: road vehicles, internal combustion engines, controlled ignition engines, ignition systems, ignition coils, specifications, electrical properties, tests, electrical tests.

Price based on 10 pages
